

沈阳化工大学本科培养方案

信息工程学院

专业名称：电子信息工程

专业代码：080701

制 定：陈 斌

审 核：孔晓光

审 定：于三三

批 准：金志浩

2021年8月

电子信息工程专业培养方案

一、培养目标

培养能在电子信息领域从事电子设备和信息系统的分析、设计、开发、运维及管理工作的德智体美劳全面发展的高素质应用型工程技术人才，成为自觉服务国家和社会的社会主义事业合格建设者和可靠接班人。

本专业毕业生在毕业后 5 年左右：

(1) 具有熟练运用工程数理知识和电子信息专业知识解决电子信息领域的电子设备及信息系统等工程项目的能力，成为电子信息领域工程师、技术骨干等；

(2) 具有运用现代工具和先进技术对电子信息领域的电子设备及信息系统进行创新性分析、设计、集成和服务的能力；

(3) 具有正确的世界观和人生观，具备有效的沟通、表达能力及项目管理能力，有良好的团队协作精神，能在工程实践中综合考虑法律、环境、社会、经济等方面因素；

(4) 具有广阔的国际视野，主动适应不断变化的国内外形势和环境，具备终生学习的能力，能够胜任不断发展的电子信息技术领域工作。

二、专业方向

信号处理与信息集成方向。

三、毕业要求

根据本专业人才培养目标以及我校电子信息工程学科多年的人才培养经验，从适应社会发展的需求出发，明确现阶段本专业的毕业能力要求及其指标点分解：

毕业能力要求	指标点
毕业要求 1： 工程知识：具备数学、自然科学、工程基础和 信息获取、传输、处理和集成相关的专业知识， 能够运用其理论和方法解决电子信息领域电子 设备和信息系统相关的复杂工程问题。	1-1. 能运用数学、自然科学、工程基础的知识，发现并表述电子信息领域的工程问题。
	1-2. 能针对电子信息领域的具体对象建立数学模型并求解。
	1-3. 能够将电子信息领域专业知识和数学模型方法用于推演、分析电子信息领域专业工程问题。
	1-4. 能够综合运用数学、自然科学、工程基础和专业知识解决电子信息领域的复杂工程问题，并对解决方案进行比较和综合。
毕业要求 2： 问题分析：能够应用数学、自然科学和工程科 学的基本原理，识别、表达、并通过文献研究 来分析电子信息领域电子设备和信息系统相关 的复杂工程问题，以获得有效结论。	2-1. 运用数学、自然科学和工程科学的基本原理，识别和判断电子信息领域电子设备和信息系统相关的复杂工程问题中的关键环节。
	2-2. 能根据电子信息基础原理和数学模型方法正确表达电子信息领域电子设备和信息系统相关的复杂工程问题。
	2-3. 能通过文献研究寻求问题的解决方案，能运用工程基础和专业基础知识，借助文献研究来分析电子信息领域电子设备和信息系统相关复杂工程过程的影响因素，寻求并获得有效结论。
毕业要求 3： 设计/开发解决方案：在综合考虑社会、健康、	3-1. 掌握电子信息领域工程设计和产品开发全周期、全流程的基本设计/开发方法和技术，了解影响设计目标和技术方案的各种因素，并能够进行系统设计。

安全、法律、文化以及环境等因素的前提下，能够针对电子信息领域电子设备和信息系统相关的复杂工程问题设计解决方案，设计满足特定需求的系统、单元（部件），并能够在设计环节中体现创新意识。	3-2. 能够设计满足特定需求的系统、单元（部件）。
	3-3. 能够在设计中考虑社会、健康、安全、法律、文化及环境等制约因素，并体现创新意识。
毕业要求 4： 研究：能够基于科学原理，采用科学方法对电子信息领域电子设备和信息系统相关的复杂工程问题进行研究，包括设计实验、分析与解释数据、并通过信息综合得到合理有效的结论。	4-1. 能够基于科学原理，通过文献研究或相关方法，调研和分析电子信息领域复杂工程问题的解决方案。
	4-2. 能够根据电子信息领域对象的特征，选择研究路线并设计可行的实验方案，采用科学的实验方法，合理规范地进行实验并获取数据。
	4-3. 能对实验结果进行分析和解释，并通过信息综合得到合理有效的结论。
毕业要求 5： 使用现代工具：能够针对电子信息领域电子设备和信息系统相关的复杂工程问题，具有开发、选择与使用恰当技术、资源、现代工程工具和信息技术工具进行工程实践的能力，包括对复杂工程问题的预测与模拟，并理解其局限性。	5-1. 具备计算机、网络及现代工程工具的知识，了解现代仪器仪表、建模和软件开发工具、EDA 仿真及设计等信息技术工具的使用原理和方法，并理解其局限性。
	5-2. 能够开发、选择与使用恰当的技术、仪器设备、信息资源、建模和软件开发工具、EDA 仿真及设计等现代工程和信息技术工具，对复杂工程问题分析、设计、研究、模拟与预测，并能够分析其局限性。
毕业要求 6： 工程与社会：能够基于电子信息相关背景知识进行合理分析，评价专业工程实践和电子信息领域复杂工程问题解决方案对社会、健康、安全、法律以及文化的影响，并理解应承担的责任。	6-1. 了解电子信息领域的技术标准体系、知识产权、产业政策和法律法规，理解不同社会文化对电子信息领域工程的影响。
	6-2. 能够分析和评价电子信息领域工程实践对社会、健康、安全、法律、文化的影响，以及这些制约因素对工程的影响，并理解应承担的责任。
毕业要求 7： 环境和可持续发展：能够理解和评价针对电子信息领域电子设备和信息系统相关的复杂工程问题工程实践对环境、社会可持续发展的影响。	7-1. 知晓和理解环境保护和可持续发展的理念和内涵。
	7-2. 能够站在环境保护和可持续发展的角度考虑电子信息领域工程实践的可持续性，评价电子信息领域工程全周期中可能对人类和环境造成的损害和隐患。
毕业要求 8： 职业规范：具有人文社会科学素养、社会责任感，能够在电子信息领域的工程实践中理解并遵守工程职业道德和规范，履行责任。	8-1. 具有正确的世界观、人生观、价值观，具有良好的人文社会科学素养、社会责任感，了解中国国情。
	8-2. 理解诚实公正、诚信守则的工程师工程职业道德和规范，理解对公众安全、健康和福祉以及环境保护的社会责任，并能在电子信息领域工程实践中遵守并承担责任。
毕业要求 9： 个人和团队：能够在具有多学科背景和多方利益诉求的项目团队中承担个体、团队成员以及负责人的角色，理解冲突、妥协与协作。	9-1. 在多学科背景工程实践团队中，能够和多学科成员沟通共事，能够独立或合作完成相应的任务。
	9-2. 在多学科背景工程实践中，理解团队成员与负责人的角色，能够组织、协调和指挥团队开展工作。
毕业要求 10： 沟通：能够就电子信息领域复杂工程问题与业界同行及社会公众进行有效沟通和交流，包括撰写报告和设计文稿、陈述发言、清晰表达或回应指令。并具备国际视野，能够在跨文化背景下进行沟通和交流。	10-1. 能够就电子信息领域专业问题与业界同行和社会公众，以口头、文稿、图表等方式进行有效的交流，理解与业界同行和社会公众交流的差异性。
	10-2. 了解电子信息领域的国际发展趋势、研究热点，具有国际化视野和外语交流能力，理解和尊重不同文化的差异性和多样性，能够在跨文化背景下进行沟通和交流。
毕业要求 11： 项目管理：理解并掌握工程管理原理与经济决策方法，并能在多学科环境中应用。	11-1. 理解并掌握工程项目中涉及的管理与经济决策方法，理解工程及产品全周期、全流程成本构成，及其涉及的工程管理及经济决策问题。
	11-2. 能够应用工程管理原理与经济决策方法对电子信息领域复杂工程问题进行有效分析和综合评价

	价，提出经济、合理的解决方案。
毕业要求 12： 终身学习：具有自主学习和终身学习的意识， 有不断学习和适应发展的能力。	12-1. 能够对自我探索和终身学习的必要性有正确认识，具有自主学习的意识。 12-2. 具有自主学习的能力，包括对技术问题的理解能力、归纳总结的能力和提出问题的能力等。

专业毕业要求应该能够支撑培养目标的达成。建立本专业毕业要求支撑培养目标实现的关系矩阵。

毕业要求支撑培养目标实现的关系矩阵

毕业要求	培养目标			
	培养目标 1	培养目标 2	培养目标 3	培养目标 4
1: 工程知识	√			
2: 问题分析	√			
3: 设计/开发解决方案	√	√		
4: 研究		√		
5: 使用现代工具		√		
6: 工程与社会		√	√	
7: 环境和可持续发展			√	
8: 职业规范			√	
9: 个人和团队			√	
10: 沟通			√	√
11: 项目管理		√	√	√
12: 终身学习				√

四、主干学科

信息与通信工程

五、专业核心课程

电路分析基础、模拟电子技术、数字电子技术、信号与系统、数字信号处理、通信原理、高频电子与通信电路、信息论与编码、电磁场与电磁波、计算机网络、计算机组成原理。

六、修业年限

本科基本学制 4 年，弹性学习年限 3-6 年，按照学分管理制度管理。

七、授予学位

学生应至少修满 165.5 学分方可毕业。符合《沈阳化工大学本科毕业生学士学位授予工作有关规定(2017 年 3 月修订)》学位授予条件者，可授予工学学士学位。

八、学分要求

课程类别	课程模块		课程性质	学分要求	小计	比例 (%)
通识教育课	通识教育必修课	思政类	必修	17	41.5	25.1
		外语类		12		
		计算机类		2.5		
		军事安全类		2		
		劳动体育类		5		
		创新创业类		2		
		心理健康类		1		
	通识教育选修课	美育类(400)	选修	2	8	4.8
		中国与世界(500)		2		
		四史(600)		1		
		经济管理类(700)		1		
传统文化(900)		2				
通识教育实践课	军训	实践	2	2	1.2	
学科平台课	学科基础课程	公共基础类	必修	73	73	68.9
		专业基础类				
	学科实践课程	-	实践			
专业教育课	专业核心课程	-	必修	11.5	35.5	
	专业选修课程	-	选修	4		
	专业实践课程	-	实践	20		
能力拓展课	专业特色课程	-	必修(或实践)	5.5	5.5	
课外实践环节	课外通识实践	人文社会实践	课外实践	4		
		身心健康实践				
		外语技能实践				
	创新创业实践	创新训练		4		
		创新大赛				
		创客活动				
生涯教育	成长规划类	1				
总学分/比例					165.5	100%

Electronic Information Engineering Major 2021 Undergraduate Education Program

I. Educational Objectives

Cultivate high-quality applied engineering and technical talents who can be engaged in the analysis, design, development, operation and maintenance and management of electronic equipment and information systems in the field of electronic information, and become a person that consciously serves the country and society. Qualified builders and reliable successors of the socialist cause.

About 5 years after graduation from this major:

(1) Have the ability to use engineering mathematical knowledge and electronic information expertise to solve engineering projects such as electronic equipment and information systems in the electronic information field, and become engineers and technical backbones in the electronic information field;

(2) Have the ability to use modern tools and advanced technology to perform innovative analysis, design, integration and service of electronic equipment and information systems in the field of electronic information;

(3) Have a correct outlook on the world and life, and have effective communication, Ability to express and project management, have a good teamwork spirit, and be able to comprehensively consider legal, environmental, social, economic and other factors in engineering practice;

(4) Have a broad international perspective, and actively adapt to changing domestic and foreign Environment, with the ability of lifelong learning, capable of working in the evolving field of electronic information technology.

II. Major direction

Signal processing and information integration direction.

III. Graduation Requirements

According to the training objectives of this major and the many years of talent training experience in the electronic information engineering discipline of our school, starting from the needs of adapting to social development, it is clear that the graduation ability requirements and index points of this major at this stage are broken down:

Graduates should obtain knowledge and competences as follows:

Graduation Requirements	Indices
Requirement 1: Engineering knowledge: possess professional knowledge related to mathematics, natural sciences, engineering foundation and information acquisition, transmission, processing and integration, and be able to use its theories and methods to solve complex	1-1. Can use basic knowledge of mathematics, natural sciences, and engineering to discover and express engineering problems in the field of electronic information.
	1-2. It can establish mathematical models and solve specific objects in the field of electronic information.
	1-3. Be able to use professional knowledge and mathematical model methods in the field of electronic information to derive and analyze professional engineering problems in the field of electronic information.

<p>engineering problems related to electronic equipment and information systems in the field of electronic information.</p>	<p>1-4. Able to comprehensively use mathematics, natural sciences, engineering foundations and professional knowledge to solve complex engineering problems in the field of electronic information, and compare and synthesize solutions.</p>
<p>Requirement 2: Problem analysis: Be able to apply the basic principles of mathematics, natural sciences and engineering sciences to identify, express, and analyze complex engineering issues related to electronic equipment and information systems in the field of electronic information through literature research to obtain effective conclusions.</p>	<p>2-1. Use the basic principles of mathematics, natural sciences and engineering sciences to identify and judge the key links in complex engineering problems related to electronic equipment and information systems in the electronic information field.</p>
	<p>2-2. Can correctly express complex engineering problems related to electronic equipment and information systems in the field of electronic information according to the basic principles of electronic information and mathematical model methods.</p>
	<p>2-3. Can find solutions to problems through literature research, use engineering foundation and professional knowledge, and use literature research to analyze the influencing factors of electronic equipment and information systems related complex engineering processes in the electronic information field, and seek and obtain effective conclusions.</p>
<p>Requirement 3: Design/development solutions: Under the premise of comprehensively considering social, health, safety, legal, cultural and environmental factors, we can design solutions to complex engineering problems related to electronic equipment and information systems in the electronic information field, and design systems and units (components) that meet specific needs , And can reflect the sense of innovation in the design process.</p>	<p>3-1. Master the basic design/development methods and technologies of the entire cycle and process of engineering design and product development in the field of electronic information, understand various factors that affect design goals and technical solutions, and be able to design systems.</p>
	<p>3-2. Able to design systems and units (components) that meet specific needs.</p>
	<p>3-3. Be able to consider social, health, safety, legal, cultural and environmental constraints in the design, and reflect the sense of innovation.</p>
<p>Requirement 4: Research: Be able to study complex engineering issues related to electronic equipment and information systems in the field of electronic information based on scientific principles and scientific methods, including designing experiments, analyzing and interpreting data, and obtaining reasonable and effective conclusions through information synthesis.</p>	<p>4-1. Be able to investigate and analyze solutions to complex engineering problems in the field of electronic information based on scientific principles and through literature research or related methods.</p>
	<p>4-2. Able to select research routes and design feasible experimental programs according to the characteristics of objects in the electronic information field, adopt scientific experimental methods, conduct experiments in a reasonable and standardized manner, and obtain data.</p>
	<p>4-3. Be able to analyze and interpret experimental results, and obtain reasonable and effective conclusions through information synthesis.</p>
<p>Requirement 5: Use modern tools: Able to address complex engineering problems related to electronic equipment and information systems in the electronic information field, and have the ability to develop,</p>	<p>5-1. Have knowledge of computers, networks and modern engineering tools, understand the principles and methods of information technology tools such as modern instrumentation, modeling and software development tools, EDA simulation and design, and understand their limitations.</p>

<p>select and use appropriate technologies, resources, modern engineering tools and information technology tools for engineering practice, including the prediction and simulation of complex engineering problems, And understand its limitations.</p>	<p>5-2. Be able to develop, select and use appropriate technology, equipment, information resources, modeling and software development tools, EDA simulation and design and other modern engineering and information technology tools to analyze, design, research, simulate and predict complex engineering problems, and Be able to analyze its limitations.</p>
<p>Requirement 6: Engineering and society: Be able to conduct a reasonable analysis based on the background knowledge of electronic information, evaluate the impact of professional engineering practices and complex engineering problem solutions in the field of electronic information on society, health, safety, law, and culture, and understand the responsibilities that should be undertaken.</p>	<p>6-1. Understand the technical standard system, intellectual property rights, industrial policies, laws and regulations in the field of electronic information, and understand the impact of different social cultures on projects in the field of electronic information.</p>
	<p>6-2. Be able to analyze and evaluate the impact of engineering practices in the field of electronic information on society, health, safety, law, and culture, as well as the impact of these constraints on the project, and understand the responsibilities that should be undertaken.</p>
<p>Requirement 7: Environment and sustainable development: Able to understand and evaluate the impact of engineering practice on the sustainable development of the environment and society for complex engineering problems related to electronic equipment and information systems in the electronic information field.</p>	<p>7-1. Know and understand the concepts and connotations of environmental protection and sustainable development.</p>
	<p>7-2. Be able to consider the sustainability of engineering practices in the field of electronic information from the perspective of environmental protection and sustainable development, and evaluate the damage and hidden dangers that may be caused to humans and the environment during the full cycle of engineering in the field of electronic information.</p>
<p>Requirement 8: Professional norms: Possess humanities and social science literacy, a sense of social responsibility, and be able to understand and abide by engineering professional ethics and norms in the field of electronic information engineering practice, and perform responsibilities.</p>	<p>8-1. Have a correct world outlook, values, outlook on life, good humanities and social science literacy, a sense of social responsibility, and an understanding of China's national conditions.</p>
	<p>8-2. Understand the engineering professional ethics and norms of honesty, fairness and integrity, understand the social responsibility for public safety, health and well-being, and environmental protection, and be able to comply with and assume responsibilities in engineering practices in the field of electronic information.</p>
<p>Requirement 9: Individuals and teams: Able to assume the roles of individuals, team members and leaders in a project team with a multi-disciplinary background and multi-party interest appeals, and understand conflicts, compromises and collaborations.</p>	<p>9-1. In a multi-disciplinary engineering practice team, able to communicate and work with multi-disciplinary members, and be able to complete corresponding tasks independently or cooperatively.</p>
	<p>9-2. In engineering practice with a multi-disciplinary background, understand the roles of team members and leaders, and be able to organize, coordinate, and direct team work.</p>
<p>Requirement 10: Communication: Able to effectively communicate and communicate with industry colleagues and the public on</p>	<p>10-1. Be able to communicate effectively with industry colleagues and the public on professional issues in the field of electronic information, through oral, manuscript, and diagrams, and understand the differences in communication with industry colleagues and the public.</p>

complex engineering issues in the field of electronic information, including writing reports and design manuscripts, making statements, expressing clearly or responding to instructions. And have an international perspective, able to communicate and exchange in a cross-cultural context.	10-2. Understand the international development trends and research hotspots in the field of electronic information, have an international vision and the ability to communicate in foreign languages, understand and respect the differences and diversity of different cultures, and be able to communicate and communicate in a cross-cultural context.
Requirement 11: Project management: Understand and master engineering management principles and economic decision-making methods, and be able to apply them in a multi-disciplinary environment.	11-1. Understand and master the management and economic decision-making methods involved in engineering projects, understand the cost composition of the whole cycle and the whole process of engineering and products, and the engineering management and economic decision-making issues involved.
	11-2. Ability to apply engineering management principles and economic decision-making methods to effectively analyze and comprehensively evaluate complex engineering problems in the field of electronic information, and to propose economic and reasonable solutions.
Requirement 12: Lifelong learning: Have the consciousness of independent learning and lifelong learning, and have the ability to continuously learn and adapt to development.	12-1. Able to have a correct understanding of the necessity of self-exploration and lifelong learning, and have the consciousness of independent learning.
	12-2. Have the ability to learn independently, including the ability to understand technical problems, the ability to summarize and ask questions, etc.

The relationship between graduation requirements and educational objectives

Graduation Requirements	Educational Objectives			
	Educational Objectives 1	Educational Objectives 2	Educational Objectives 3	Educational Objectives 4
1: Engineering Knowledge	√			
2: Problem Analysis	√			
3: Design/Development Solutions	√	√		
4: Research		√		
5: Use Modern Tools		√		
6: Engineering and Society		√	√	
7: Environment and Sustainable Development			√	
8: Career Planning			√	
9: Individuals and Teams			√	
10: Communicate			√	√
11: Project Management		√	√	√
12: Lifelong Learning				√

IV. Major Subject

Information and Communication Engineering

V. Core Courses

Basis of Circuit Analysis, Analog Electronic Technology, Digital Electronic Technology, Signals and Systems, Digital Signal Processing, Principles of Communication, High Frequency Electronics and Communication Circuits, Information Theory and Coding, Electromagnetic Field and Electromagnetic Wave, Computer Networks, Principle of Computer Organization.

VI. Educational System

The basic school system for undergraduates is 4 years, and the flexible study period is 3-6 years, which is managed in accordance with the credit system.

VII. Confer Degrees

Students should take at least 165.5 credits to graduate. Those who meet the requirements for degree granting in the "Shenyang University of Chemical Technology undergraduate graduates' bachelor's degree award work regulations (revised in March 2017)" can be awarded a bachelor's degree in engineering.

VIII. Credit Requirements

Course Type	Course Modules		Course Nature	Credit requirement	Subtotal	Proportion (%)
General Education	General Education (Compulsory)	Ideological and Political Courses	Compulsory	17	41.5	25.1
		Foreign Language Courses		12		
		Computer Courses		2.5		
		Military and Safety Courses		2		
		Labor and Sport Education		5		
		Innovation and Entrepreneurship		2		
		Mental Health		1		
	General Education (Optional)	Aesthetic Education(400)	Optional	2	8	4.8
		China and the world(500)		2		
		Four Histories(600)		1		
		Economic Management(700)		1		
		Traditional Culture(900)		2		
	General Education (Practice)	Military Training	Practice	2	2	1.2
Discipline Education	Basic Courses	Public basic class	Compulsory	73	73	
		Professional foundation				
	Basic Practice Sessions	-	Practice			
Specialized Education	Core Courses	-	Compulsory	11.5	35.5	68.9
	Optional Courses	-	Optional	4		
	Specialized Practice Sessions	-	Practice	20		
Competency Development	Individualized Courses	-	Compulsory (or Practice)	5.5	5.5	
Extracurricular practice	Extracurricular General Education Practice	Culture and Society Practice	Extracurricular Practice	4		
		Mentally and Physically Practice				
		Foreign Language Proficiency Training Practice				
	Extracurricular Characteristic Practice	Innovative Training		4		
		Innovation Competition				
		Maker Activities				
	Career Education	Growth Planning Courses		1		
Total/Proportion					165.5	100

九、电子信息工程专业教学进程表

Table of Teaching Schedule for Electronic Information Engineering Major

课程类别 Course Type	课程性质 Course Nature		课程号 Course Code	课程名称 Course Name	学分 Cre.	总学 时数 T. C.H	学时分配 Credit Hour Distribution				各学期周学时分配 Weekly Hours Per Semester								备注 Notes	
							讲课 Lec.	实验 Exp.	上机 Pro.	课外 实践 Pra.	一	二	三	四	五	六	七	八		
											1st	2nd	3rd	4th	5th	6th	7th	8th		
通识教育课 General Education	必修 Compulsory	思政类 Ideological and Political Courses	0710093001	思想道德与法治 Ideological Morality and the Rule of Law	3.0	48	32			16		2								
			0710053001	中国近现代史纲要 Outline of Chinese Contemporary and Modern History	3.0	48	32			16	2									
			0710103001	马克思主义基本原理* Basic Principles of Marxism*	3.0	48	32			16				2						
			0710133001	毛泽东思想和中国特色社会主义理论体系概论* Mao Zedong Thought and Theory of Socialism with Chinese Characteristics *	3.0	48	32			16				2						
			0710123001	习近平新时代中国特色社会主义思想概论 Introduction to Xi Jinping Thought on Socialism with Chinese Characteristics for a New Era	3.0	48	40			8					3					
			0710012301	形势与政策 Current Situation and Policies	2.0	64	64				2	2	2	2	2	2	2	2		
			0211003101	大学外语I College English I	3.0	48	48				3									
	0211003201	大学外语II* College English II*	3.0	48	48					3										
	0241003301	大学外语III College English III	3.0	48	48						3							五选一		

课程类别 Course Type	课程性质 Course Nature		课程号 Course Code	课程名称 Course Name	学分 Cre.	总学时数 T. C.H	学时分配 Credit Hour Distribution				各学期周学时分配 Weekly Hours Per Semester								备注 Notes	
							讲课 Lec.	实验 Exp.	上机 Pro.	课外 实践 Pra.	一	二	三	四	五	六	七	八		
											1st	2nd	3rd	4th	5th	6th	7th	8th		
通识教育课 General Education	必修 Compulsory	外语类 Foreign Language Courses	0241003301	大学外语III（进阶英语） College English III（Advanced English CET 6-Orientated）	3.0	48	48						3							
				大学外语III（英语口语表达与交流） College English III（English Oral Expression and Communication）	3.0	48	48							3						
				大学外语III（跨文化交际） College English III（Intercultural Communication）	3.0	48	48							3						
				大学外语III（英语写作表达与交流） College English III（English Writing Expression and Communication）	3.0	48	48							3						
			0241003401	大学外语IV* College English IV*	3.0	48	48								3					
				大学外语IV（进阶英语） College EnglishIV（Advanced English CET 6-Orientated）	3.0	48	48									3				
				大学外语IV（英语口语表达与交流） College EnglishIV（English Oral Expression and Communication）	3.0	48	48										3			
				大学外语IV（跨文化交际） College English IV（Intercultural Communication）	3.0	48	48											3		
					大学外语IV（英语写作表达与交流） College English IV（English Writing Expression and Communication）	3.0	48	48									3			
			计算机类 Computer Courses	1511372002	C 语言程序设计 C Programming Language	2.5	44	32			12			2						

课程类别 Course Type	课程性质 Course Nature		课程号 Course Code	课程名称 Course Name	学分 Cre.	总学 时数 T. C.H	学时分配 Credit Hour Distribution				各学期周学时分配 Weekly Hours Per Semester								备注 Notes	
							讲课 Lec.	实验 Exp.	上机 Pro.	课外 实践 Pra.	一	二	三	四	五	六	七	八		
											1st	2nd	3rd	4th	5th	6th	7th	8th		
通识教育课 General Education	必修 Compulsory	军事安全类 Military and Safety Courses	0710081001	军事理论 Military Theory	1.0	16						2								
			1510261302	安全教育 Safety Education	1.0	16	16				1	1	1	1	1	1	1			
		劳动体育类 Labor and Sport Education	2640021001	劳动教育 Labour Education	1.0	16	16					2								
			0410011101	大学体育I College Physical Education I	1.0	36		36			2									
			0410021201	大学体育II College Physical Education II	1.0	36		36				2								
			0410031301	大学体育III College Physical Education III	1.0	36		36					2							
			0410041401	大学体育 IV College Physical Education IV	1.0	36		36						2						
			创新创业类 Innovation and Entrepreneurship courses	1557011002	创造性思维与创新方法 Creative Thinking and Innovative Methods	1.0	16	16						2						
		1740011001		创业基础 Entrepreneurial Foundation	1.0	16	16							2						
		心理健康类 Mental Health Courses	0510041001	大学生心理与健康教育 Mental and Health Education for College Students	1.0	16	16				2									
		小计 Subtotal					41.5	780	552	144	12	72								
			选修 Optional	分为经济管理类（1.0）、美育类（2.0）、四史（1.0）、传统文化（2.0）、中国与世界（2.0）课程类5个模块 每个模块最多选修2.0学分，每学期最多选修2门课程。 Including 5 modules: Economic Management（1.0）, Aesthetic Education（2.0）, Four Histories（1.0）, Traditional Chinese Culture（2.0）, China and The world（2.0）. Up to 2.0 credits per module and up to 2 courses per semester.																

课程类别 Course Type	课程性质 Course Nature		课程号 Course Code	课程名称 Course Name	学分 Cre.	总学时数 T. C.H	学时分配 Credit Hour Distribution				各学期周学时分配 Weekly Hours Per Semester								备注 Notes		
							讲课 Lec.	实验 Exp.	上机 Pro.	课外 实践 Pra.	一	二	三	四	五	六	七	八			
											1st	2nd	3rd	4th	5th	6th	7th	8th			
通识教育课 General Education			小计 Subtotal		8.0	128	128														
	实践 Practice		0415102011	军训 Military Training	2.0	48				48	+2								集中		
合计 Total					51.5	956	680	144	12	120											
学科平台课 Discipline Education	必修 Compulsory	数学与自然科学类 Natural Science & Mathematics	0310004101	高等数学 I* Advanced Mathematics I*	4.5	80	72			8	6										
			0310005201	高等数学 II* Advanced Mathematics II*	5.5	96	88			8		6									
			0310032001	线性代数 Linear Algebra	2.0	32	32					3									
			0310042001	概率论与数理统计 Probability and Statistics	2.0	32	32							2							
			1510251002	复变函数 Function of Complex Variable	1.5	24	24						2								
			1519501002	面向信息科学的离散数学 Discrete Mathematics in Information Science	1.0	16	16							2							
			0310063101	大学物理 I* University Physics I*	3.0	48	46	2					3								
			0310063201	大学物理 II* University Physics II*	3.0	48	46	2						3							
		1111042003	化学工艺学 Chemical Process Technology	1.0	16	16								2							
				工程基础类 Foundation Engineering	1510141002	电气工程制图及 CAD Electrical Engineering Drawing and CAD	1.5	26	20				6			2					
		1510163002	电路分析基础* Basis of Circuit Analysis*		3.5	56	56							4							

课程类别 Course Type	课程性质 Course Nature		课程号 Course Code	课程名称 Course Name	学分 Cre.	总学时数 T. C.H	学时分配 Credit Hour Distribution				各学期周学时分配 Weekly Hours Per Semester								备注 Notes				
							讲课 Lec.	实验 Exp.	上机 Pro.	课外 实践 Pra.	一	二	三	四	五	六	七	八					
											1st	2nd	3rd	4th	5th	6th	7th	8th					
学科平台课 Discipline Education	必修 Compulsory	工程基础类 Foundation Engineering	1510913002	模拟电子技术* Analog Electronic Technology*	3.5	60	48	12				3											
			1510923002	数字电子技术* Digital Electronic Technology*	3.5	60	48	12					3										
			1514822002	电磁场与电磁波* Electromagnetic Field and Electromagnetic Wave*	2.0	32	32							2									
			1514883002	信号与系统 I* Signals and Systems I*	3.0	50	44	6						4									
	专业基础类 Subject Foundation Requisite			1514811002	电子信息工程专业概论 Introduction to Electronic Information Engineering	1.0	16	16				2											
				1514892002	数字信号处理* Digital Signal Processing*	2.5	42	36	6					3									
				1514902002	高频电子与通信电路* High Frequency Electronics and Communication Circuits*	2.5	42	36	6									3					
				1514832002	信息论与编码* Information Theory and Coding*	2.0	32	32										2					
				1517122002	通信原理 I* Principles of Communication I*	2.5	42	36	6								3						
				1513272002	算法与数据结构 Algorithm and Data Structure	2.5	44	32		12					3								
				1514922002	数据库原理与应用 Principle and Application of Database	2.0	36	24		12							3						
				1517062002	计算机网络* Computer Networks*	2.5	44	32		12								2					
				1526982002	计算机组成原理* Principle of Computer Organization*	2.5	42	36	6								3						

课程类别 Course Type	课程性质 Course Nature		课程号 Course Code	课程名称 Course Name	学分 Cre.	总学 时数 T. C.H	学时分配 Credit Hour Distribution				各学期周学时分配 Weekly Hours Per Semester								备注 Notes	
							讲课 Lec.	实验 Exp.	上机 Pro.	课外 实践 Pra.	一	二	三	四	五	六	七	八		
											1st	2nd	3rd	4th	5th	6th	7th	8th		
学科平台课 Discipline Education	必修 Compulsory	专业基础类 Subject Foundation Requisite	1515751002	电子信息类专业外语 Specialized English on Telecommunication	1.0	16	16							2						
			1515761002	电子信息类科技论文写作与文献检索 Scientific Paper Writing and Documentation Retrieval for Electronic Information Field	1.0	16	16								2					
			小计 Subtotal		62.5	1048	932	58	42	16										
	实践 Practice	0310081011	大学物理实验 Physical Experiment of College	1.0	24	6	18					√								分散
		2110071031	金工实习 Metalworking Practice	1.0	24		24				+1									集中
		1514242022	工程数学实践 Engineering Mathematics Practice	2.0	48		48						+2							集中
		1510150012	电路分析基础实验 Circuit Analysis Experiment	0.5	12		12				√									分散
		1514501022	模拟电子课程设计 Course Design for Analog Electronic Technique	1.0	24		24							√						分散
		1514511022	数字电子课程设计 Course Design with Digital Electronic Technique	1.0	24		24							√						分散
		1512212032	电子工艺实习 Electronic Process Practice	2.0	48		48						+2							集中
		1516991022	电子线路 CAD 设计实践 CAD Design Practice of Electronic Circuit	1.0	24		24									√				分散
		1514351032	工程认识实习 Engineering Cognition Practice	1.0	24		24							√						分散
		小计 Subtotal		10.5	252	6	246													

课程类别 Course Type	课程性质 Course Nature	课程号 Course Code	课程名称 Course Name	学分 Cre.	总学时数 T. C.H	学时分配 Credit Hour Distribution				各学期周学时分配 Weekly Hours Per Semester								备注 Notes		
						讲课 Lec.	实验 Exp.	上机 Pro.	课外 实践 Pra.	一	二	三	四	五	六	七	八			
										1st	2nd	3rd	4th	5th	6th	7th	8th			
合计 Total				73.0	1300	938	304	42	16											
专业教育课 Specialized Education	必修 Compulsory	1524932002	面向对象程序设计 Object-oriented Programming	2.0	36	24		12					3							
		1524482002	Python 机器学习 Python Machine Learning	2.5	48	24		24						2						
		1513822002	单片机原理与应用 The Application and Principal of MCU	2.5	44	32	12							3						
		1514662002	化工过程信息处理与传输 Chemical Process Information Processing and Transmission	2.0	32	32										2				
		1524942002	数字信号处理器原理及应用 Principle and Application of Digital Signal Processors	2.5	44	32	12									3				
		小计 Subtotal				11.5	204	144	24	36										
	选修 Optional	1536972002	嵌入式系统原理 Embedded System Principle	2.0	36	24	12									2				
		1534872002	语音信号处理 Speech Signal Processing	2.0	36	24		12							2					
		1537242002	Matlab 程序设计 Matlab Programming	2.0	36	24		12				2								
		1534962002	C#程序设计 C# Programming	2.0	36	24		12							2					
		1534863002	大数据原理与技术 Principle and Technology of Big Data	3.0	56	32		24								4				

课程类别 Course Type	课程性质 Course Nature	课程号 Course Code	课程名称 Course Name	学分 Cre.	总学 时数 T. C.H	学时分配 Credit Hour Distribution				各学期周学时分配 Weekly Hours Per Semester								备注 Notes	
						讲课 Lec.	实验 Exp.	上机 Pro.	课外 实践 Pra.	一	二	三	四	五	六	七	八		
										1st	2nd	3rd	4th	5th	6th	7th	8th		
专业教育课 Specialized Education	选修 Optional	1533912002	FPGA 原理及设计 Principle and Design of FPGA	2.0	36	24	12							2					
		1534842002	Python 数据分析与应用 Python Data Analysis and Application	2.0	36	24		12				2							
		1538563002	ZigBee 技术应用及无线传感器网络 ZigBee Technology Application and Wireless Sensor Networks	3.0	52	40	12							3					
		1537073002	移动通信 Mobile Communication	3.0	52	40	12								3				
		1531552002	自动控制原理II The Principle of Automatic Control II	2.0	34	28	6					2							
		小计 Subtotal				4.0													
	(修读要求 4 学分, Study Requirements 4 Credits)																		
	实践 Practice	1514522022	信号处理课程设计 Course design of Signal Processing	2.0	48		48											+2	集中
		1514551022	数字信号处理器课程设计 Course Design of Digital Signal Processor	1.0	24		24											+1	集中
		1514531022	程序实践 The Practice of Programming	1.0	24		24							√					分散
		1514152032	生产实习 Production Practice	2.0	48		48											+2	集中
		1514971042	毕业设计 (论文) Graduation Design (Thesis)	14.0															+17
小计 Subtotal				20.0	144		144												

课程类别 Course Type	课程性质 Course Nature		课程号 Course Code	课程名称 Course Name	学分 Cre.	总学 时数 T. C.H	学时分配 Credit Hour Distribution				各学期周学时分配 Weekly Hours Per Semester								备注 Notes	
							讲课 Lec.	实验 Exp.	上机 Pro.	课外 实践 Pra.	一	二	三	四	五	六	七	八		
											1st	2nd	3rd	4th	5th	6th	7th	8th		
合计 Total					36.5															
能力拓展课 Competency Development	必修或实践 Compulsory or Practice		1524852002	数字图像处理* Digital Image Processing*	2.5	44	32	12							3					
			1514563022	信息系统集成综合设计 Information System Integration Comprehensive Design	3.0	72		72										+3		集中 CDIO 课程
			小计 Subtotal				5.5	116	32	84										
			总计 Sum																	
课外环节 Extracurricular practice	课外实践 Extracurricular practice	人文社会实践 Culture and Society Practice	1513401032	社会调查 Social Survey	0.5	12				12							0.5	分散		
		身心健康社会实践 Mentally and Physically Practice	0410050751	课外体育锻炼 Extracurricular Physical Exercise	0.5	12				12								0.5	分散	
			2640030011	劳动教育实践 Labour Education Practice	0.5	12				12		0.5							分散	
			0510070311	心理健康辅导 Mental Health Counseling	0.5	12				12								0.5	分散	
		外语技能实践类 Foreign Language Proficiency Training Practice	0210010011	外语技能实践（初级） Foreign Language Proficiency Training Practice (elementary)	2.0	48				48				2						二选一
			0210020011	外语技能实践（高级） Foreign Language Proficiency Training Practice (advanced)	2.0	48				48				2						

课程类别 Course Type	课程性质 Course Nature		课程号 Course Code	课程名称 Course Name	学分 Cre.	总学 时数 T. C.H	学时分配 Credit Hour Distribution				各学期周学时分配 Weekly Hours Per Semester								备注 Notes
							讲课 Lec.	实验 Exp.	上机 Pro.	课外 实践 Pra.	一	二	三	四	五	六	七	八	
											1st	2nd	3rd	4th	5th	6th	7th	8th	
课外环节 Extracurricular practice	课外实践 Extracurricular practice	能力与创新实践 Capability and Innovation Practice	1513414022	大学生素质拓展与创新实践 Quality Development and Innovation Practice	4.0	96					1~8 学期依据《沈阳化工大学创新创业实践学分认定办法》由创新创业学院认定								分散
		成长规划类 Growth Planning Courses	1510271312	职业规划与就业指导 Career Planning and Employment Guidance	1.0	40	40												
小计 Subtotal																			

理论课 1 学分 16 学时，实验课程、上机等 1 学分 24 学时，体育课 1 学分 36 学时，集中实践环节 1 个教学周计 1 学分，学分最小单位为 0.5,课程名称中画*为考试课。

Note: “Cre. (Credits)”, “T.C.H. (Total Credit Hours)”, “Lec. (Lecture)”, “Exp. (Experiment)”, “Pro. (Programming)”, “Pra. (Practice)”.

十、电子信息工程专业学士学位课程一览表

A list of bachelor's degree programs in Electronic Information Engineering

课程类别 Course Type	模块名称 Modules	序号 No.	课程编号 Course Codes	课程名称 Course Name	学分 Credits	开课学期 Semester	
通识教育课 General Education	政治理论 Political Theory	1	0710103001	马克思主义基本原理* Basic Principles of Marxism*	3	4	
		2	0710133001	毛泽东思想和中国特色社会主义理论体系 概论* Mao Zedong Thought and Theory of Socialism with Chinese Characteristics*	3	4	
学科平台课 Discipline Education	数学 Mathematics	3	0310004101	高等数学I* Advanced Mathematics I*	4.5	1	
	物理 Physics	4	0310063101	大学物理 I* University Physics I*	3	2	
	工程基础类 Foundations of Engineering	5	1510163002	电路分析基础* Basis of Circuit Analysis*	3.5	2	
		6	1510913002	模拟电子技术* Analog Electronic Technology*	3.5	3	
		7	1514883002	信号与系统 I* Signals and Systems I*	3.0	3	
		8	1510923002	数字电子技术* Digital Electronic Technology*	3.5	4	
		9	1514822002	电磁场与电磁波* Electromagnetic Field and Electromagnetic Wave*	2.0	4	
		10	1514892002	数字信号处理* Digital Signal Processing*	2.5	4	
	专业基础 Subject Foundation Requisite	11	1517122002	通信原理 I* Principles of Communication I*	2.5	5	
		12	1526982002	计算机组成原理* Principle of Computer Organization*	2.5	5	
		13	1514832002	信息论与编码* Information Theory and Coding*	2.0	6	
		14	1517062002	计算机网络* Computer Networks*	2.5	6	
		15	1514902002	高频电子与通信电路* High Frequency Electronics and Communication Circuits*	2.5	6	
	专业教育课 Specialized Education	信号处理与信息 集成 Signal Processing and Information Integration	16	1514662002	化工过程信息处理与传输 Chemical Process Information Processing and Transmission	2.0	6
			17	1524852002	数字图像处理 Digital Image Processing*	2.5	6

说明：关于学士学位课的具体要求见《沈阳化工大学关于学士学位课程水平审核制度的若干规定》

十一、全学程实践环节周历安排 Weekly Calendar of all Practice Sessions

学期	1	2	3	4	5	6	7	8	9	10	11	12	13	14	15	16	17	18	19	20	21	备注
一		☆	☆															::	::	●		军训
二													※					::	::	●	●	金工实习
三				P	P													::	::	●		电子工艺实习
四															P	P		::	::	●	●	工程数学实践
五																		::	::	●		
六																△		::	::	●	●	电子线路 CAD 设计 实践
七	△	△	△	/	/	△															●	信号处理课程设 计、数字信号处 理器、生产实习、 信息系统集成综 合设计
八	=	=	=	=	=	=	=	=	=	=	=	=	=	=	=	=	=					毕业设计 (论文)

23

符号说明(Symbol Description):

※金工实习||Metalworking Practice △课程设计||Curriculum Design /生产实习||Specialized Production Practice L 专业实验||Specialty Experiment P 各类实
训、学年论文||Practical Training、Term Paper :: 考试||Examination ▼ 认识实习||Cognition Practice ☆军训||Military Training = 毕业设计 (论文)
||Graduation Project(Thesis) ●小学期||Primary Term

十二、课程体系配置图 Curriculum System Configuration Diagram

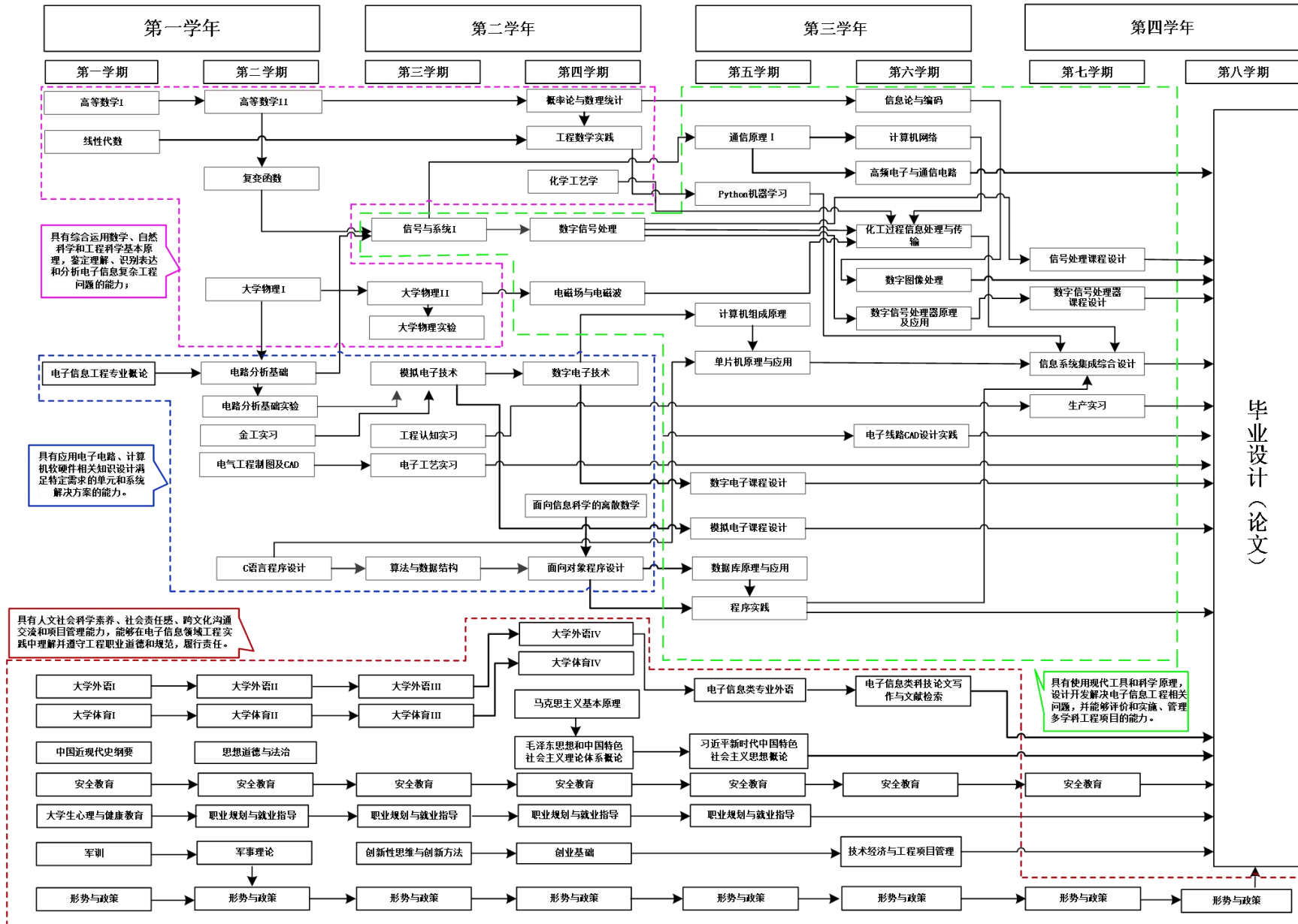

课程 (Courses)	毕业能力要求 (Graduation Requirements)																												
	1.1	1.2	1.3	1.4	2.1	2.2	2.3	3.1	3.2	3.3	4.1	4.2	4.3	5.1	5.2	6.1	6.2	7.1	7.2	8.1	8.2	9.1	9.2	10.1	10.2	11.1	11.2	12.1	12.2
大学生素质拓展与创新实践 Quality Development and Innovation Practice																H													
化工过程信息处理与传输 Chemical Process Information Processing and Transmission				M			M	M				M																	